

# เครื่องรักษาอุณหภูมิช็อกโกแลต ควบคุมอุณหภูมิช็อกโกแลต

## TEMPERING CHOCOLATE MACHINE

### รุ่น FUTURA EX



### SCREW PUMP REMOVABLE IN 5 MINUTES

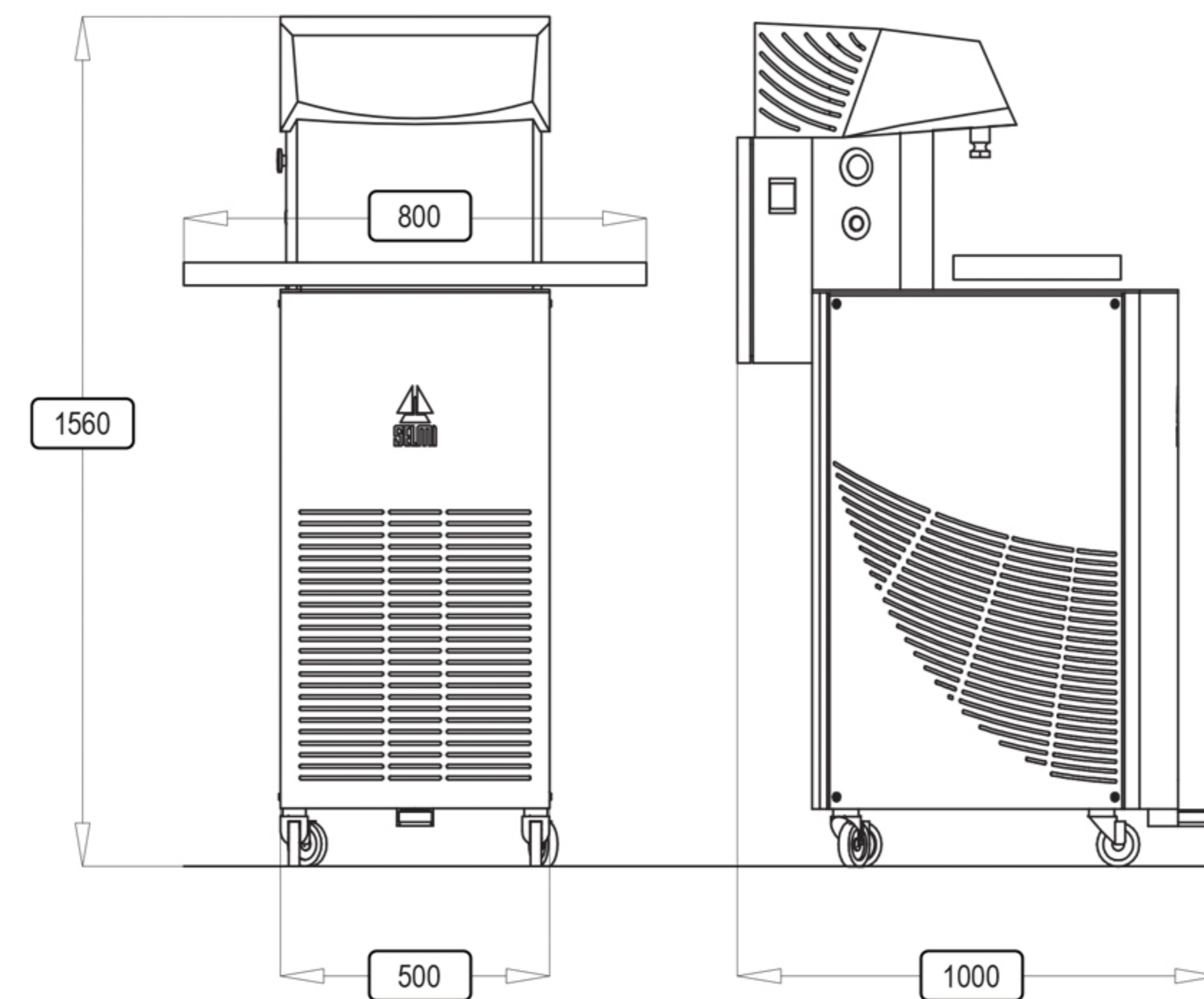
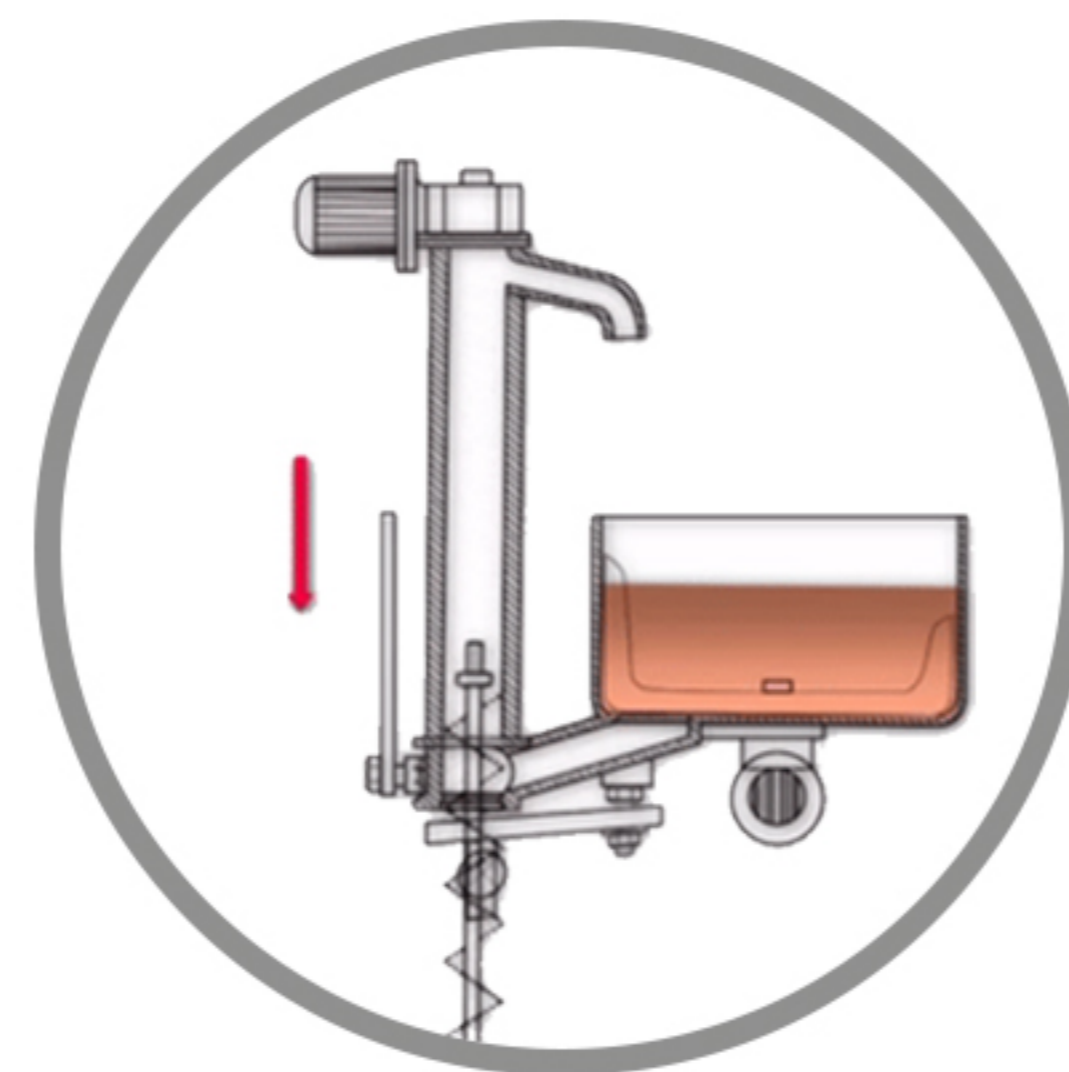

### Mechanical Characteristics

Overall Dimensions	[L] 500 x [W] 1000 x [H] 1560 mm.
Empty weight	[kg] 190
Material in contact with food	inox AISI 304L
Gaskets	PTFE
Tank capacity	[kg] 35
No. of pivoting wheel	4

### Cooling System Characteristics

Cooling group	[Fr/h] 2200
Refrigerant gas	R452A
Refrigerant gas quantity	[g] 600
Coolant	[l], 2
	70% water, 30% phosphate-free glycol

### Electrical characteristics

Total installed power	[KW] 2, 5
Supply voltage	[VAC] 400/220
Number of phases	1*/ 3
Frequency	[Hz] 50 / 60
Auxiliary voltage	[Vdc] +24
Enclosure degree of protection	IP65
Connection type : industrial plug	16A - 5 poles

### Process Features

Tank reducer ratio	1 : 60
Maximum mixer revolutions	[rpm] 23
Hourly production	[kg/h] 170

**OFFICIAL DISTRIBUTOR**

Installation & After Sales Service

**Belt & Bearings**

บริษัท เบลท แอนด์ แบริ่งส์ จำกัด  
69/27 ถนนวิภาวดีรังสิต แขวงสามเสนใน  
เขตพญาไท กรุงเทพฯ 10400  
[www.beltandbearings.co.th](http://www.beltandbearings.co.th)

Call Us Now!  
02-6449001-3

@BELTER

