

เครื่องรักษาอุณหภูมิช็อกโกแลต ควบคุมอุณหภูมิช็อกโกแลต

TEMPERING CHOCOLATE MACHINE

รุ่น COLOR EX



SCREW PUMP REMOVABLE IN 5 MINUTES

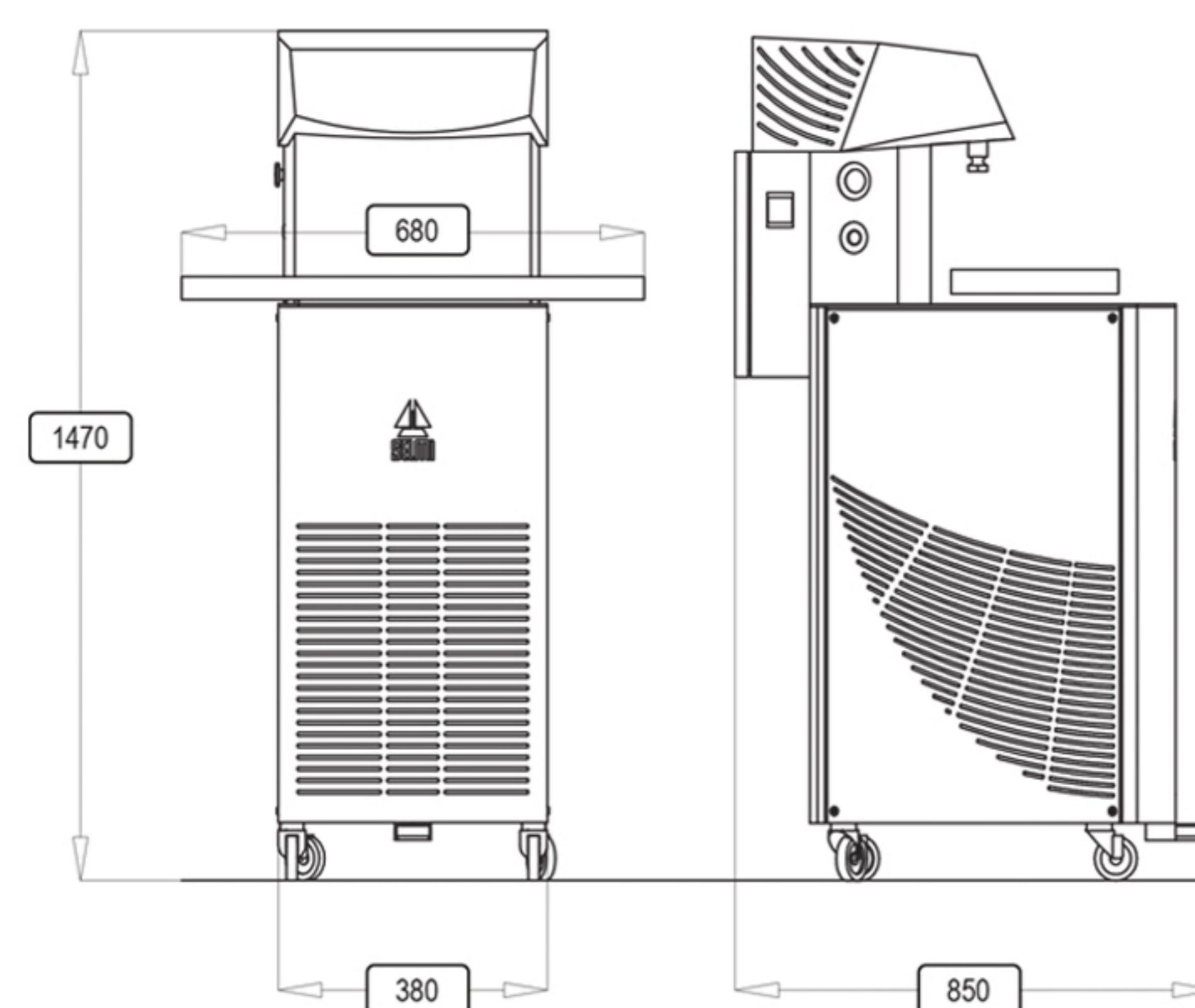
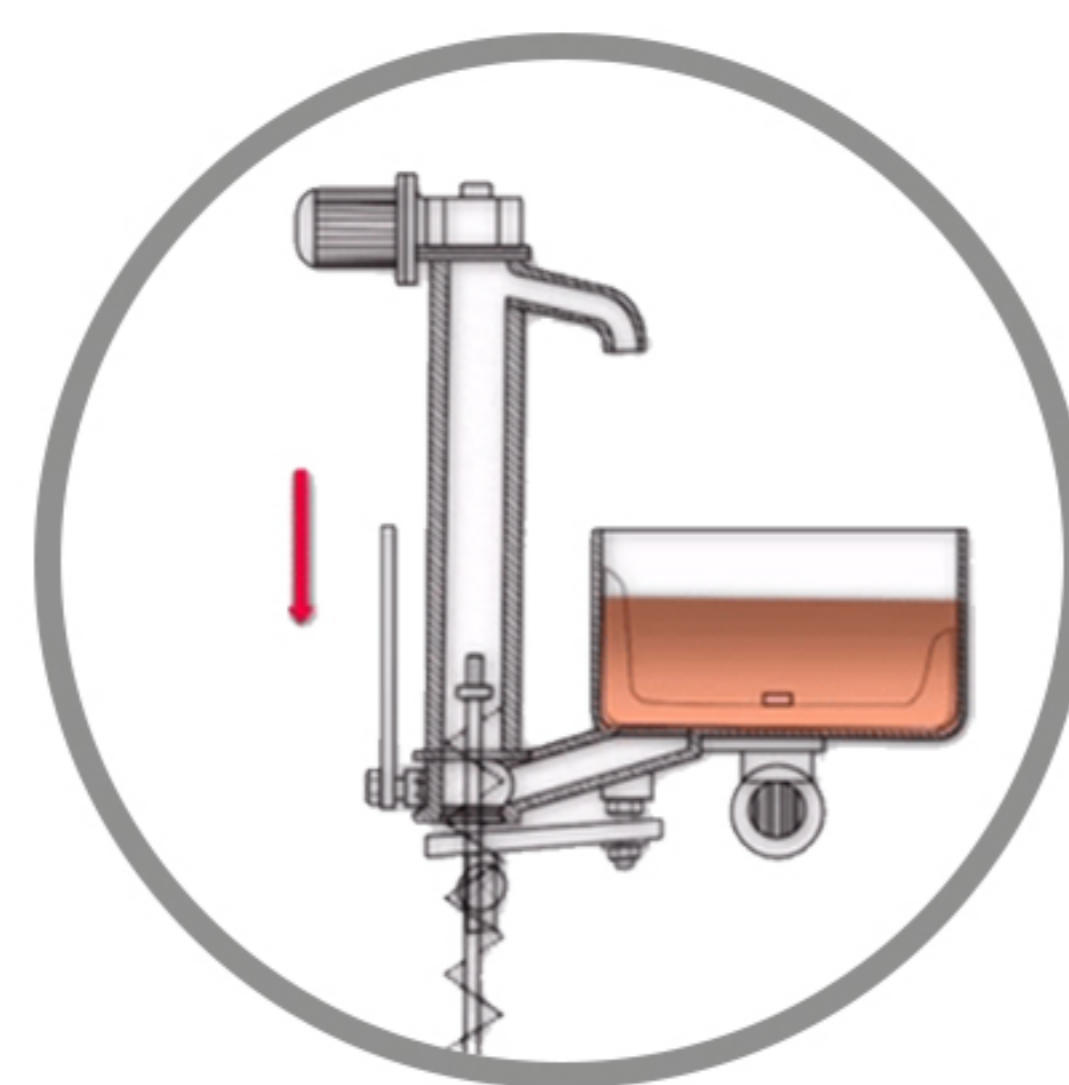

Mechanical Characteristics

Overall Dimensions	[L] 300 x [W] 850 x [H] 1470 mm.
Empty weight	[kg] 137
Material in contact with food	inox AISI 304L
Gaskets	PTFE
Tank capacity	[kg] 12
No. of pivoting wheel	4

Cooling System Characteristics

Cooling group	[Fr/h] 900
Refrigerant gas	R452A
Refrigerant gas quantity	[g] 500
Coolant	[l] 1, 7
	70% water, 30% phosphate-free glycol

Electrical characteristics

Total installed power	[KW] 1
Supply voltage	[VAC] 400/220
Number of phases	1*/ 3
Frequency	[Hz] 50 / 60
Auxiliary voltage	[Vdc] +24
Enclosure degree of protection	IP65
Connection type : industrial plug	16A - 5 poles

Process Features

Tank reducer ratio	1 : 50
Maximum mixer revolutions	[rpm] 27, 6
Hourly production	[kg/h] 55

OFFICIAL DISTRIBUTOR

Installation & After Sales Service

Belt & Bearings

บริษัท เบลท แอนด์ แบริ่งส์ จำกัด
69/27 ถนนวิภาวดีรังสิต แขวงสามเสนใน
เขตพญาไท กรุงเทพฯ 10400
www.beltandbearings.co.th

Call Us Now!
02-6449001-3

@BELTER

