

# เครื่องเคลือบช็อกโกแลต เครื่องเคลือบคลูกฟิวด้วยช็อกโกแลตหรือน้ำตาล

## Chocolate coating panning machine

### รุ่น COMFIT MAXI

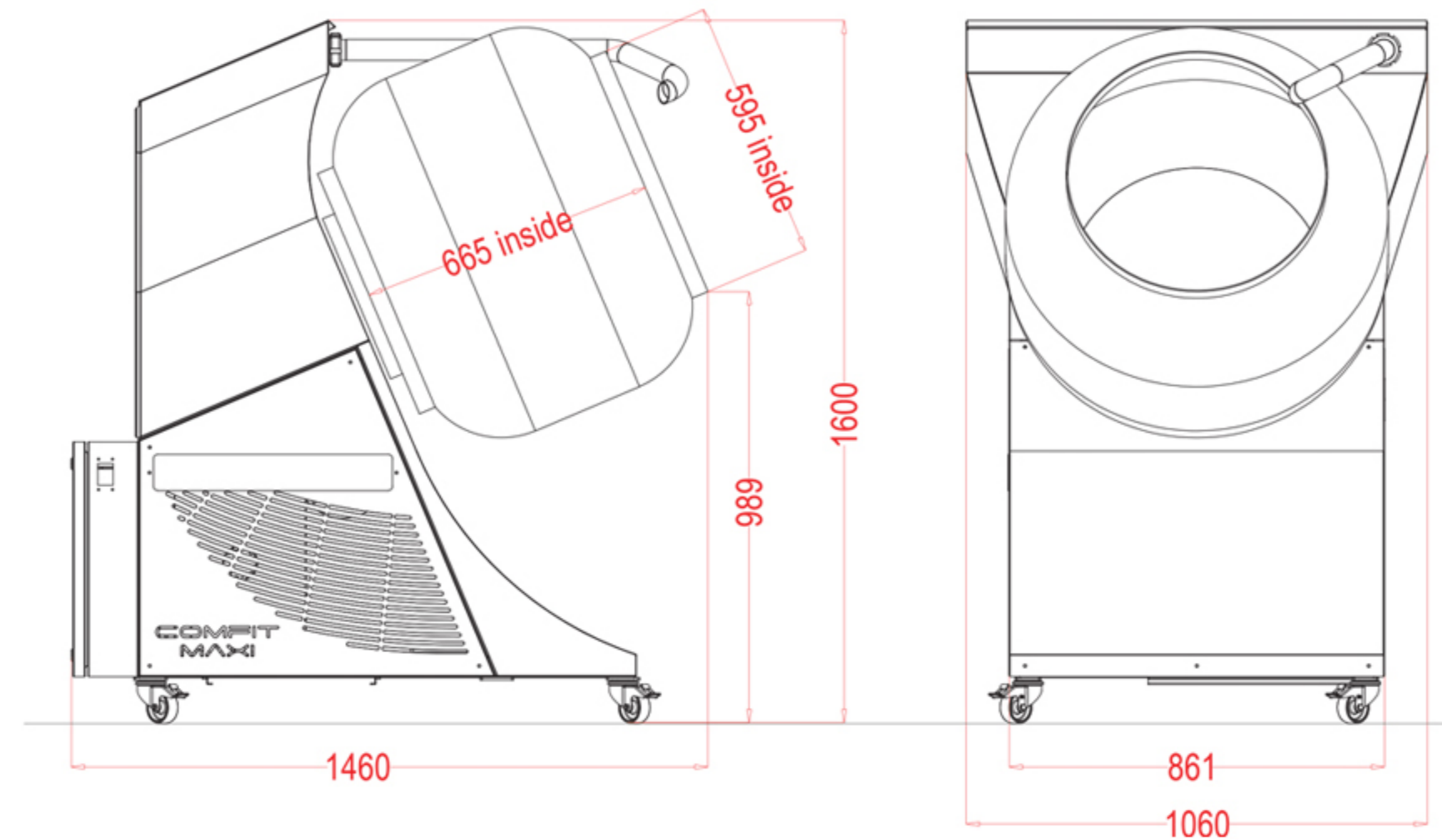

#### Mechanical Characteristics

Overall Dimensions	[L] 1060 x [W] 1460 x [H] 1600 mm.
Empty weight	[kg] 300
Material in contact with food	inox AISI 304L
Gaskets	PTFE
Tank capacity	[kg] 50/60
No. of pivoting wheel	4

#### Cooling System Characteristics

Cooling group	[Fr/h] 1900
Refrigerant gas	R452A
Refrigerant gas quantity	[g] 600

#### Electrical characteristics

Total installed power	[KW] 2, 5
Supply voltage	[VAC] 400
Number of phases	3
Frequency	[Hz] 50 / 60
Auxiliary voltage	[Vdc] +24
Enclosure degree of protection	IP65
Connection type : industrial plug	16A - 5 poles

#### Characteristics pneumatic system

Mimimun work pressure	[bar] 6
Maximum flow rate	[l/min] 300
Air Characteristics	filtered, dry and de-oiled

#### Process Features

Hourly production	[kg] 40
-------------------	---------

**OFFICIAL DISTRIBUTOR**

Installation & After Sales Service

**Belt & Bearings**

บริษัท เบลท แอนด์ แบริ่งส์ จำกัด  
69/27 ถนนวิภาวดีรังสิต แขวงสามเสนใน  
เขตพญาไท กรุงเทพฯ 10400  
[www.beltandbearings.co.th](http://www.beltandbearings.co.th)

Call Us Now!  
02-6449001-3

@BELTER

